

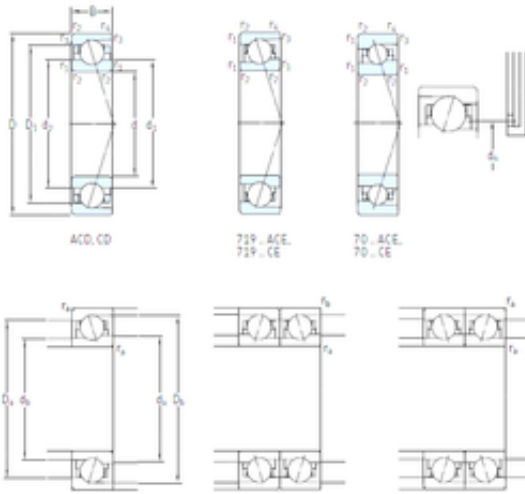

BEARING DRIVESHAFT, INC.



100 mm x 140 mm x 20 mm SKF 71920
ACD/HCP4A angular contact ball bearings

Bearing No. 71920 ACD/HCP4A

71920 ACD/HCP4A Bearing 2D drawings and 3D CAD models

Size	100x140x20 mm
Bore Diameter	100 mm
Outer Diameter	140 mm
Width	20 mm
d	100 mm
D	140 mm
B	20 mm
C	20 mm
d1	112,3 mm
d2	112,3 mm
r1 min.	1,1 mm
r2 min.	1,1 mm
r3 min.	0,6 mm
r4 min.	0,6 mm
D1	127,7 mm
D2	130,7 mm
da min.	106 mm
Da max.	134 mm
db min	106 mm
ra max.	1 mm
rb max.	0,6 mm
dh	115,6 mm
Db max	136 mm
Weight	0,67 Kg
Basic dynamic load rating (C)	57,2 kN



BEARING DRIVESHAFT, INC.

Basic static load rating (C ₀)	63 kN
(Grease) Lubrication Speed	9 000 r/min
(Oil) Lubrication Speed	15 000 r/min
Fatigue load limit (P _u)	2,4
d ₁	112.3 mm
d ₂	112.3 mm
D ₁	127.7 mm
r _{1,2} min.	1.1 mm
r _{3,4} min.	0.6 mm
a	38.1 mm
d _a min.	106 mm
d _b min.	106 mm
D _a max.	134 mm
D _b max.	136 mm
r _a max.	1 mm
r _b max.	0.6 mm
d _n	115.6 mm
Basic dynamic load rating C	57.2 kN
Basic static load rating C ₀	63 kN
Fatigue load limit P _u	2.4 kN
Attainable speed for grease lubrication	9000 r/min
Attainable speed for oil-air lubrication	15000 r/min
Ball diameter D _w	12.7 mm
Number of balls z	26
Reference grease quantity G _{ref}	10.5 cm ³
Preload class A G _A	360 N
Static axial stiffness, preload class A	283 N/ μ m
Preload class B G _B	720 N
Static axial stiffness, preload class B	373 N/ μ m



BEARING DRIVESHAFT, INC.

Preload class C G_C	1440 N
Static axial stiffness, preload class C	498 N/ μ m
Preload class D G_D	2880 N
Static axial stiffness, preload class D	680 N/ μ m
Calculation factor f	1.23
Calculation factor f_1	0.98
Calculation factor f_{2A}	1
Calculation factor f_{2B}	1.07
Calculation factor f_{2C}	1.12
Calculation factor f_{2D}	1.17
Calculation factor f_{HC}	1.04
Calculation factor e	0.68
Calculation factor (single, tandem) Y_2	0.87
Calculation factor (single, tandem) Y_0	0.38
Calculation factor (single, tandem) X_2	0.41
Calculation factor (back-to-back, face-to-face) Y_1	0.92
Calculation factor (back-to-back, face-to-face) Y_2	1.41
Calculation factor (back-to-back, face-to-face) Y_0	0.76
Calculation factor (back-to-back, face-to-face) X_2	0.67
Mass bearing	0.67 kg